



Quantum Optics is the study of the quantized electromagnetic field, where the basic element of radiation is the photon, and the interaction of the field with matter. Of particular concern are the so-called non-classical states of the quantized field. These include photon number states, squeezed states, entangled light beams, etc. A classical like state of the field is the coherent state, the light produced by a phase stabilized laser. Non-classical states of light are practical importance in the field of quantum information.

Quantum Information is the study of the processing of information in the form of qubits which are representations of information by quantum states. Because of the superposition principle, quantum information processing, such as in a quantum computer, can proceed at a much faster rate than is possible in a classical computer. Quantum information science includes not only quantum computing, but also quantum cryptography, quantum communication, and quantum enhanced metrology. Many, if not most of the physical realizations of quantum information processing are quantum optical.

Research Projects in Quantum Optics/Quantum information at Lehman College:

### (1) Quantum Metrology with Entangled States

Using non-classical states, particularly entangled coherent states of the form

$$|\psi\rangle = \frac{1}{\sqrt{2}} \left[ |\alpha\rangle|0\rangle + e^{i\theta}|0\rangle|\alpha\rangle \right]$$

for ultra-precise, Heisenberg-limited, phase shift measurements where the phase uncertainty goes as  $\Delta\phi = 1/\bar{N}$ ,  $\bar{N} = |\alpha|^2$  being the average photon number.

Interferometry with this level of sensitivity will be required to detect very weak signals such as gravitational waves.

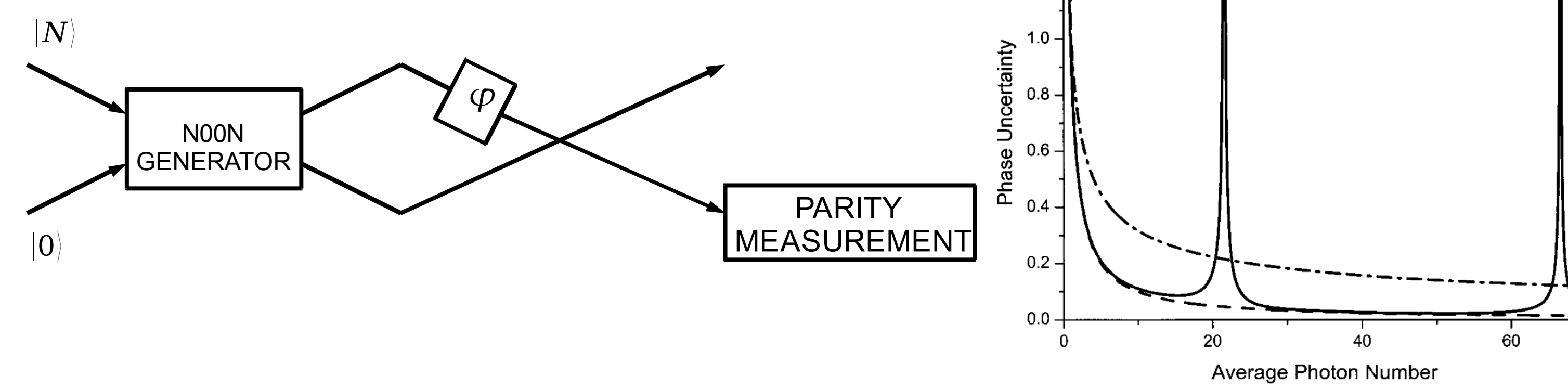

### (2) Spin Squeezing and Precision Atomic or Ionic Spectroscopy

Spin squeezing is an effect where the quantum fluctuations in one component of the spin are reduced (by non-classical spin states). The effect can be useful for performing ultra-precise frequency measurements approaching the Heisenberg limit for frequency standards, or for the construction of more accurate atomic clocks.

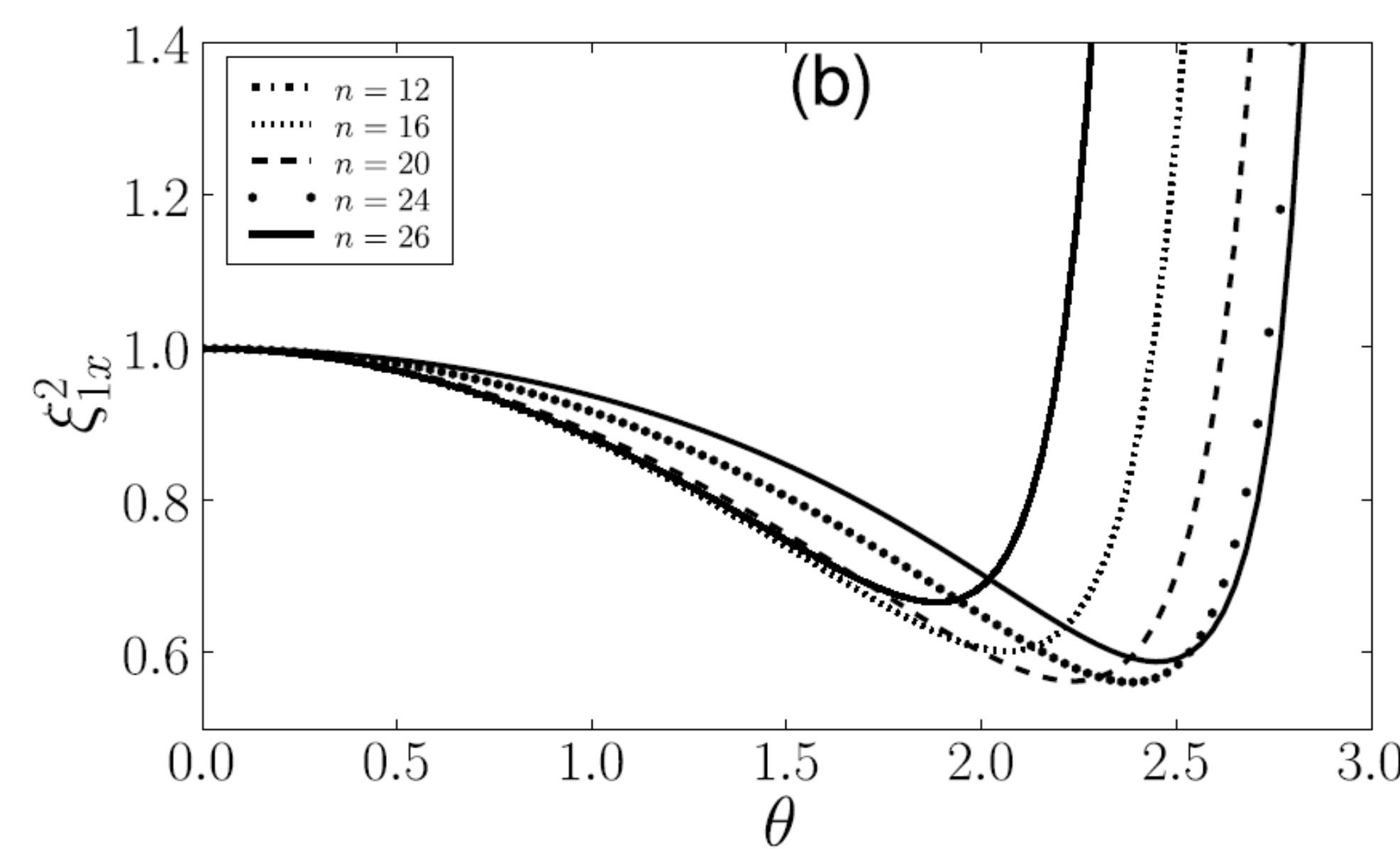

### (3) Generation of non-classical state with interferometers and projective measurements.

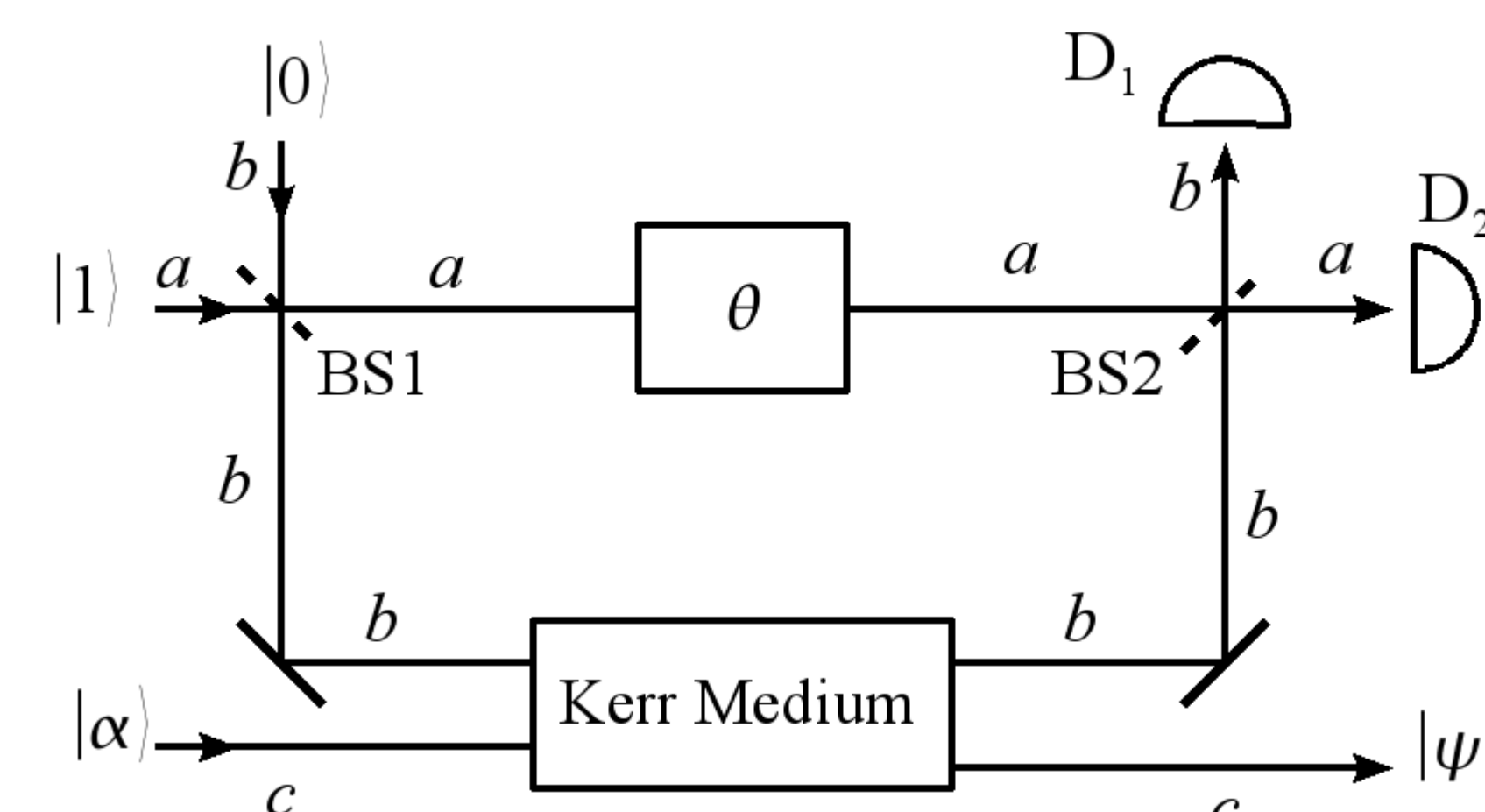

### (4) Quantum non-demolition measurements of photon number

The goal is to measure the photon number with resolution at the level of a single photon, especially for large photon numbers. This is an important goal for various problems in quantum information processing, including for quantum metrology (interferometry).

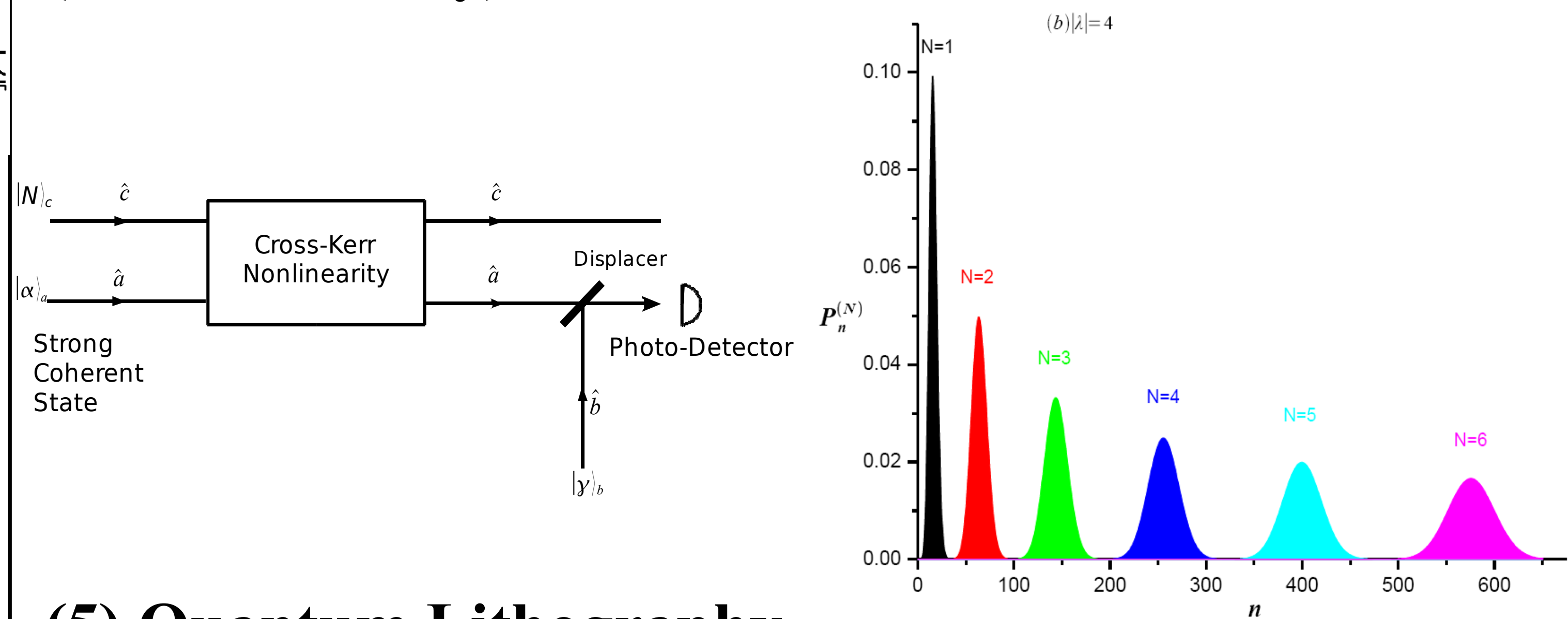

### (5) Quantum Lithography

Entangled beams of light can be used to exceed the Rayleigh limit for the transfer of images onto a substrate provided there is multiphoton absorption.

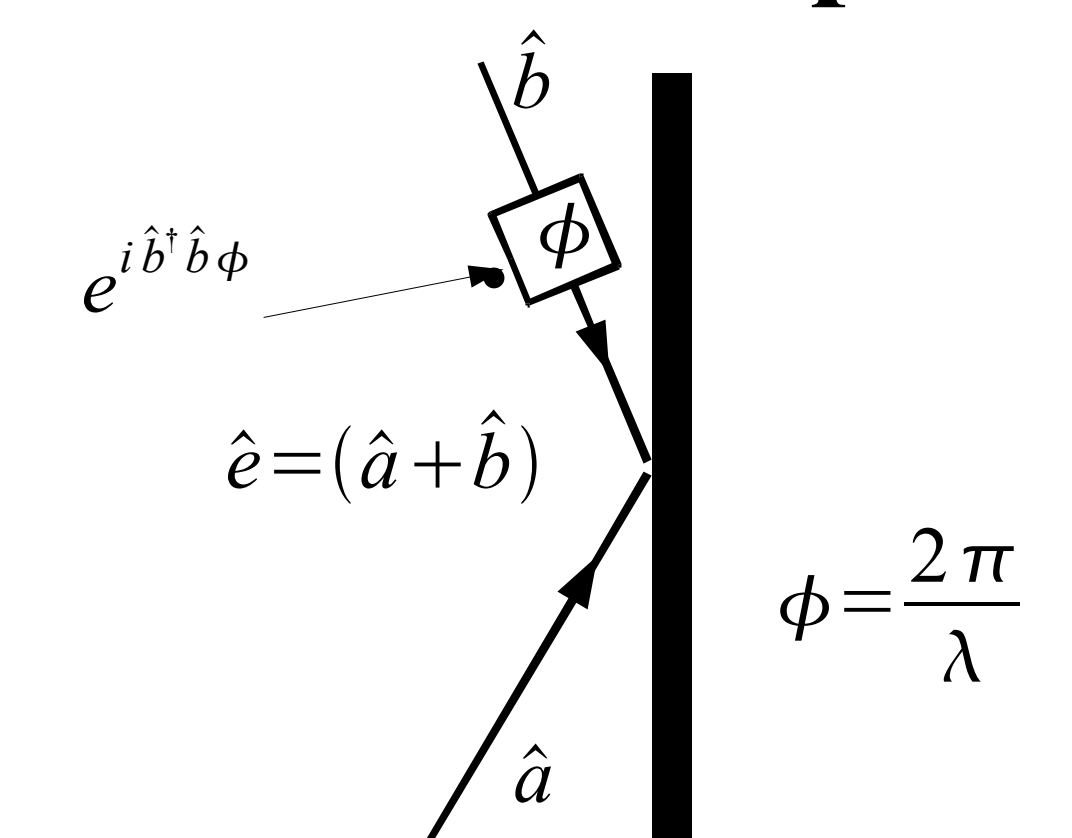

(6) Fundamental test of quantum mechanics on a large scale; Bell's inequalities, GHZ states, etc. using optical states, collective states of atomic ensembles, and Bose-Einstein condensates. Experimental violations of Bell inequalities falsifies the local realistic hidden variable theories.

